

UCF 211

Square flanged ball bearing unit with set screw locking, cast iron, JIS standards

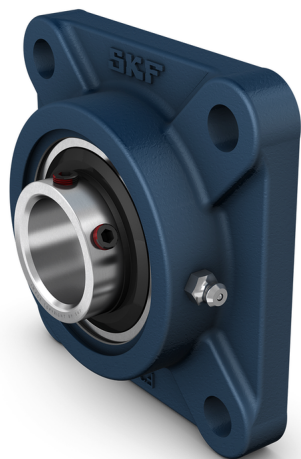

These square flanged ball bearing units are compliant with Japanese Industrial Standards (JIS). They consist of an insert bearing, with an extended inner ring and grub screw locking, suitable for applications where the direction of rotation is constant or alternating. The bearing is mounted in a housing, which can be bolted to a machine wall or frame. Ball bearing units can accommodate moderate initial misalignment, but normally do not permit axial displacement.

- Resist high levels of contamination
- Designed for hightemperatures and speeds
- Accommodate relatively heavy loads
- Cost-effective

Overview

Dimensions

Bearing width, total	55.6 mm
Centre distance between bolt holes	130 mm
Housing overall width	43 mm
Shaft diameter	55 mm

Performance

Basic dynamic load rating	43.6 kN
Basic static load rating	29 kN
Limiting speed	3 000 r/min

Properties

Bore type	Cylindrical
Coating	Without
Fastening bolt hole type	Plain
Flanged housing type	Square
Housing type	Flanged
Lubricant	Grease
Material, bearing	Bearing steel
Material, housing	Cast iron
Number of bolt holes for fasteners	4
Relubrication hole	With
Relubrication nipple	With
Retaining feature, inner ring	Set screws
Rubber seating ring	Without

Sealing type	Contact, standard
Sealing, bearing	Seal and flinger on both sides
Sealing, unit	Without

Technical Specification

Compliance with standard	JIS
Purpose specific	For material handling applications
Housing material	Cast iron
Sealing solution	Standard seals with additional flingers

Dimensions

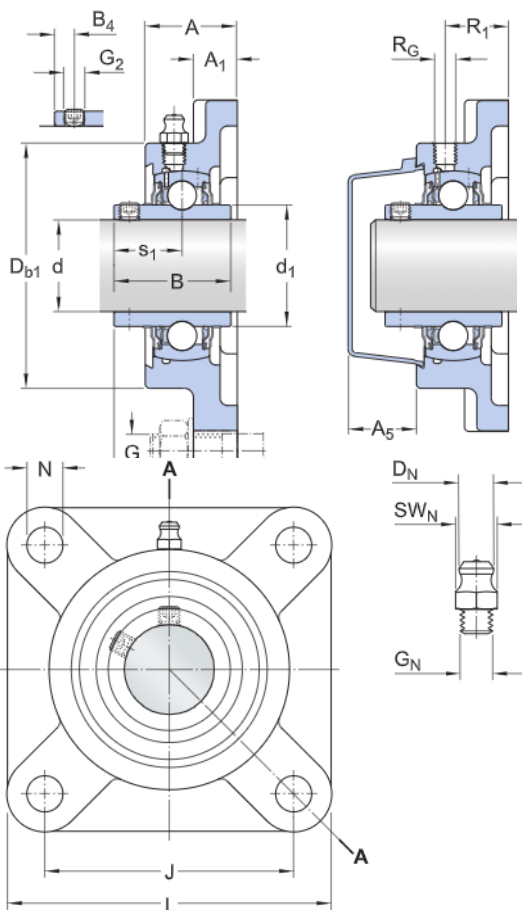

d	55 mm	Bore diameter
d ₁	≈ 70 mm	Outer diameter inner ring
A	43 mm	Overall width
A ₁	18 mm	Flange width
A ₅	37.5 mm	Standout of end cover
B	55.6 mm	Width of inner ring
B ₄	9.5 mm	Distance from locking device side face to thread centre
D _{b1}	130 mm	Top external diameter
J	130 mm	Distance between attachment bolts
L	162 mm	Overall length
N	19 mm	Diameter of attachment bolt hole
s ₁	33.4 mm	Distance from locking device side face to raceway centre
T	58.4 mm	Overall unit width

Grease fitting

D _f	6.589 mm	Diameter of head sphere of grease fitting
S _v	11.11 mm	Hexagonal key size for the grease fitting

G ₁ 1/8-27 NPT	Thread of grease fitting
---------------------------	--------------------------

Threaded hole

R _G 1/8-27 NPT	Housing thread for grease fitting
---------------------------	-----------------------------------

R ₁ 29 mm	Axial position of the housing thread
----------------------	--------------------------------------

Calculation data

Basic dynamic load rating	C	43.6 kN
Basic static load rating	C ₀	29 kN
Fatigue load limit	P _u	1.25 kN
Limiting speed		3 000 r/min
with shaft tolerance h6		

Mass

Mass bearing unit	3.45 kg
-------------------	---------

Mounting information

Set screw	G ₂	M10x1.25
Hexagonal key size for set screw		5.08 mm
Recommended tightening torque for set screw		16.5 Nm
Recommended diameter for attachment bolts, mm	G	16 mm
Recommended diameter for attachment bolts, inch	G	0.625 in

Included products

Housing	F 211/Y
Bearing	UC 211

Associated products

End cover

ECY 211

Terms and conditions

By accessing and using this website / app owned and published by AB SKF (publ.) (556007-3495 · Gothenburg) ("SKF"), you agree to the following terms and conditions:

Warranty Disclaimer and Limitation of Liability

Although every care has been taken to assure the accuracy of the information on this website / app, SKF provides this information "AS IS" and DISCLAIMS ALL WARRANTIES, EXPRESS OR IMPLIED, INCLUDING, BUT NOT LIMITED TO, IMPLIED WARRANTIES OF MERCHANTABILITY AND FITNESS FOR A PARTICULAR PURPOSE. You acknowledge that your use of this website / app is at your sole risk, that you assume full responsibility for all costs associated with use of this website / app, and that SKF shall not be liable for any direct, incidental, consequential, or indirect damages of any kind arising out of your access to, or use of the information or software made available on this website / app. Any warranties and representations in this website / app for SKF products or services that you purchase or use will be subject to the agreed upon terms and conditions in the contract for such product or service. Further, for non-SKF websites / apps that are referenced in our website / app or where a hyperlink appears, SKF makes no warranties concerning the accuracy or reliability of the information in these websites / apps and assumes no responsibility for material created or published by third parties contained therein. In addition, SKF does not warrant that this website / app or these other linked websites / apps are free from viruses or other harmful elements.

Copyright

Copyright in this website / app copyright of the information and software made available on this website / app rest with SKF or its licensors. All rights are reserved. All licensed material will reference the licensor that has granted SKF the right to use the material. The information and software made available on this website / app may not be reproduced, duplicated, copied, transferred, distributed, stored, modified, downloaded or otherwise exploited for any commercial use without the prior written approval of SKF. However, it may be reproduced, stored and downloaded for use by individuals without prior written approval of SKF. Under no circumstances may this information or software be supplied to third parties.

This website /app includes certain images used under license from Shutterstock, Inc.

Trademarks and Patents

All trademarks, brand names, and corporate logos displayed on the website / app are the property of SKF or its licensors, and may not be used in any way without prior written approval by SKF. All licensed trademarks published on this website / app reference the licensor that has granted SKF the right to use the trademark. Access to this website / app does not grant to the user any license under any patents owned by or licensed to SKF.

Changes

SKF reserves the right to make changes or additions to this website / app at any time.